

Features

- Dual-In-line-Package(DIP)or SMD, Easy to mount on PCB
- Barometric pressure measurable

Applications

- Industrial instrumentation
- Medical device
- Barometer, Altimeter
- Altitude compensation

Part number for ordering

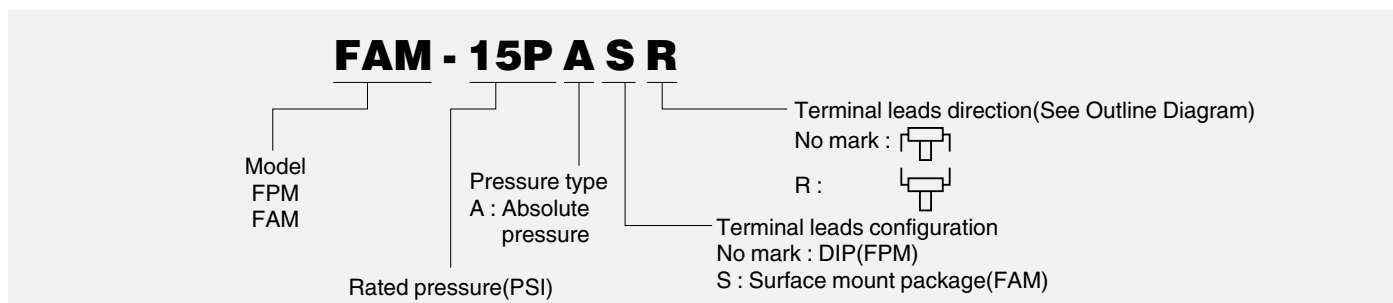

Pressure type	Absolute pressure	
	FPM	FAM
Model		
Package configuration	Dual-In-line-Package(DIP)	Surface mount package

Measurable pressure range(kPa)	Part number for ordering		
-66.7~+66.7	FPM-15PA	FPM-15PAR	FAM-15PASR

Specifications

Model/Rated pressure	15PA	Unit
Recommended operating conditions		
Pressure type	Absolute pressure	—
Rated pressure	34.66~168.0	kPa·abs
	0.3535~1.713	kg/cm ² ·abs
Measurable pressure range	0~168.0	kPa·abs
Pressure media	Non-corrosive gas	—
Excitation current (Constant)	1.5	mADC
Absolute maximum rating		
Maximum load pressure	Twice of rated pressure	—
Maximum excitation current	3	mADC
Operating temperature	-20~100	°C
Storage temperature	-40~120	°C
Operating humidity	30~80 (No dew condensation)	%RH
Electric performances/characteristics (Excitation current I=1.5mA constant, Ambient temperature Ta=25°C)		
Full scale span voltage	80~160	mV
Offset voltage	50~130 (at 101.3kPa·abs)	mV
Bridge impedance	4000~6000	Ω
Mechanical response time		
	2 (For the reference)	msec
Accuracy	Temperature sensitivity of offset (TSO)	±3
	Temperature coefficient of sensitivity (TCS)	2.5
	Linearity	±0.3
	Pressure hysteresis	±0.2

■ Outline dimensions ■

Unit (mm)

FPM (Absolute pressure)

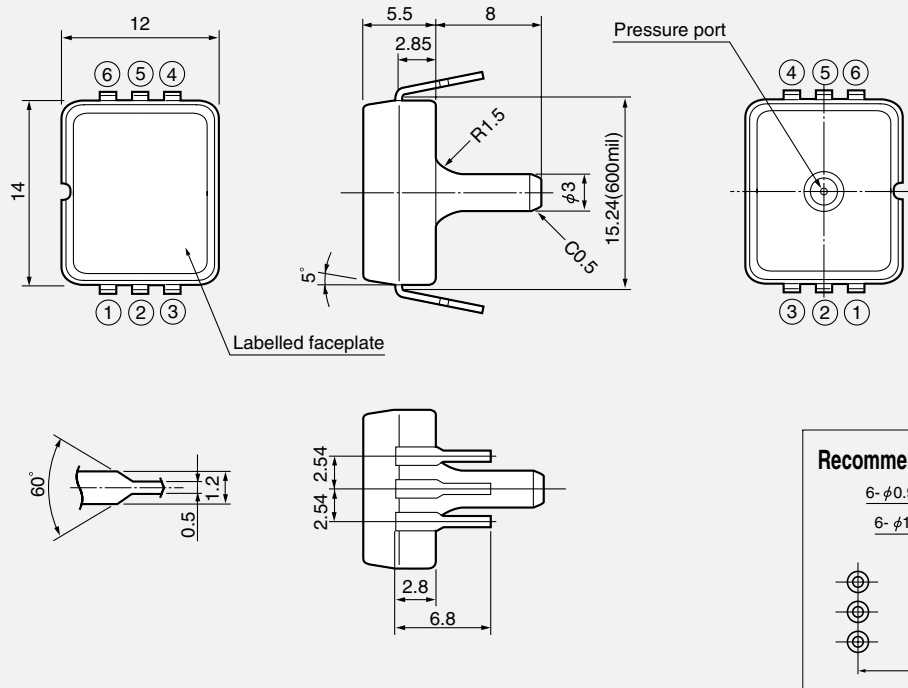

FPM-R (Absolute pressure)

Unit (mm)

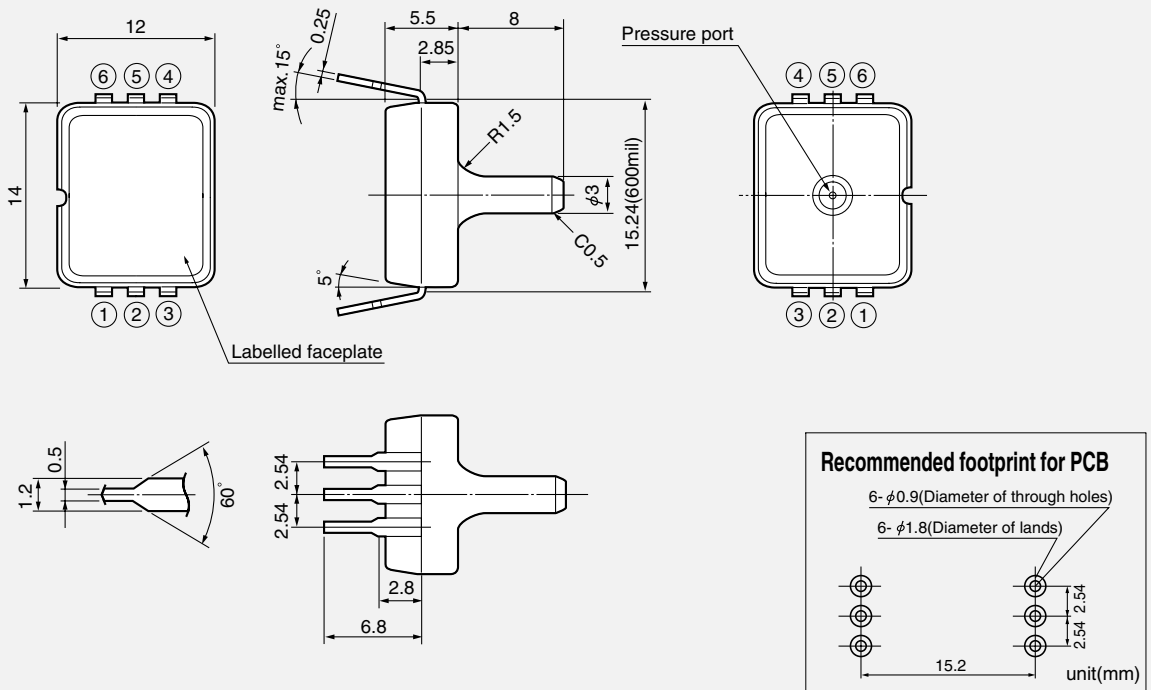

■ Outline dimensions ■

Unit (mm)

FAM

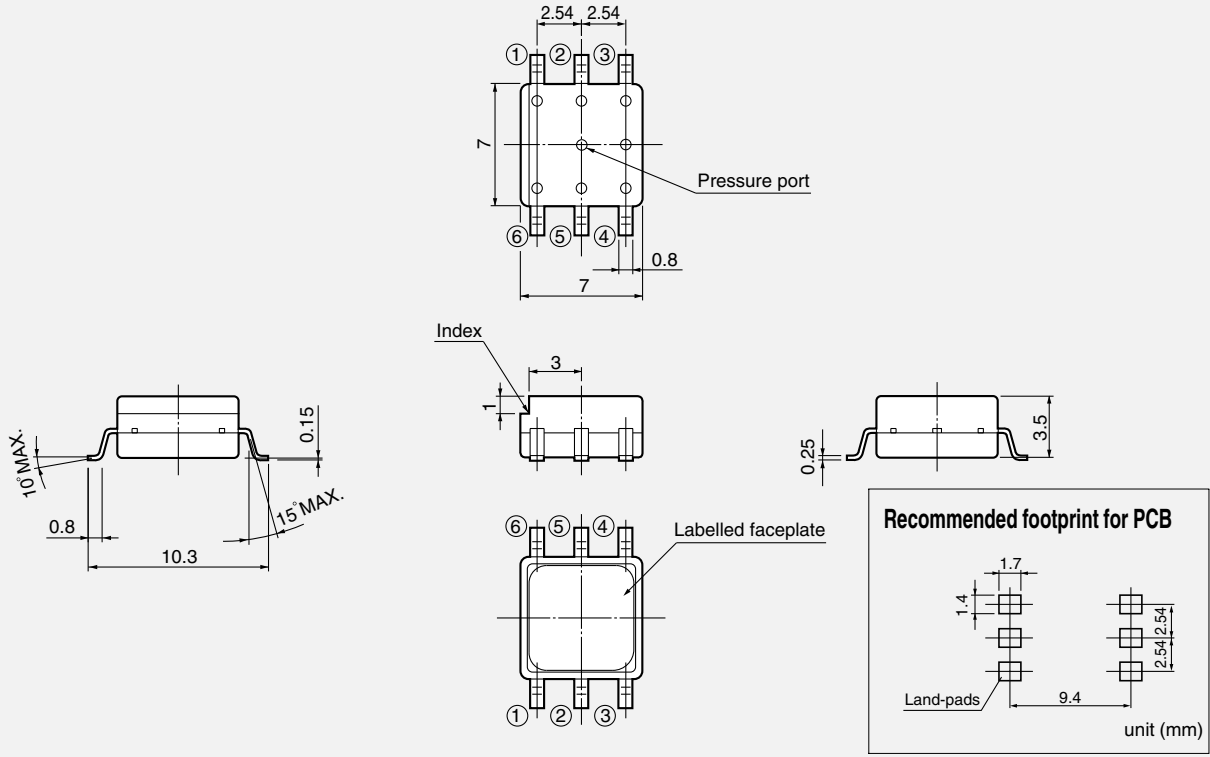

■ Connection diagram ■

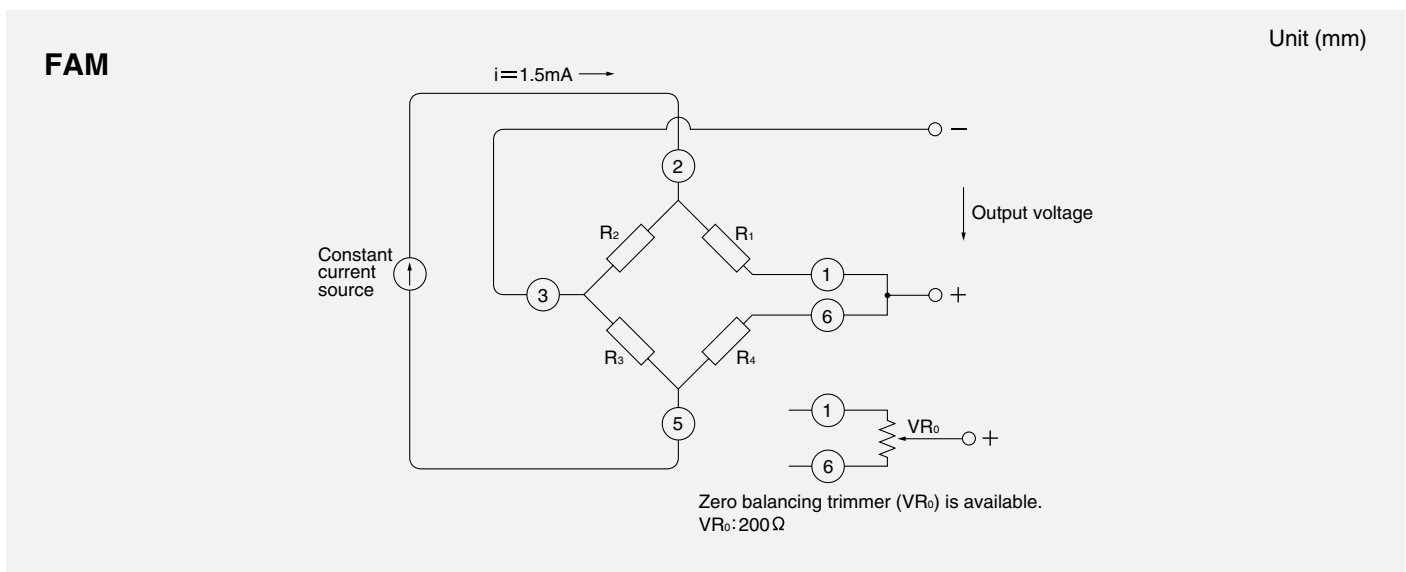
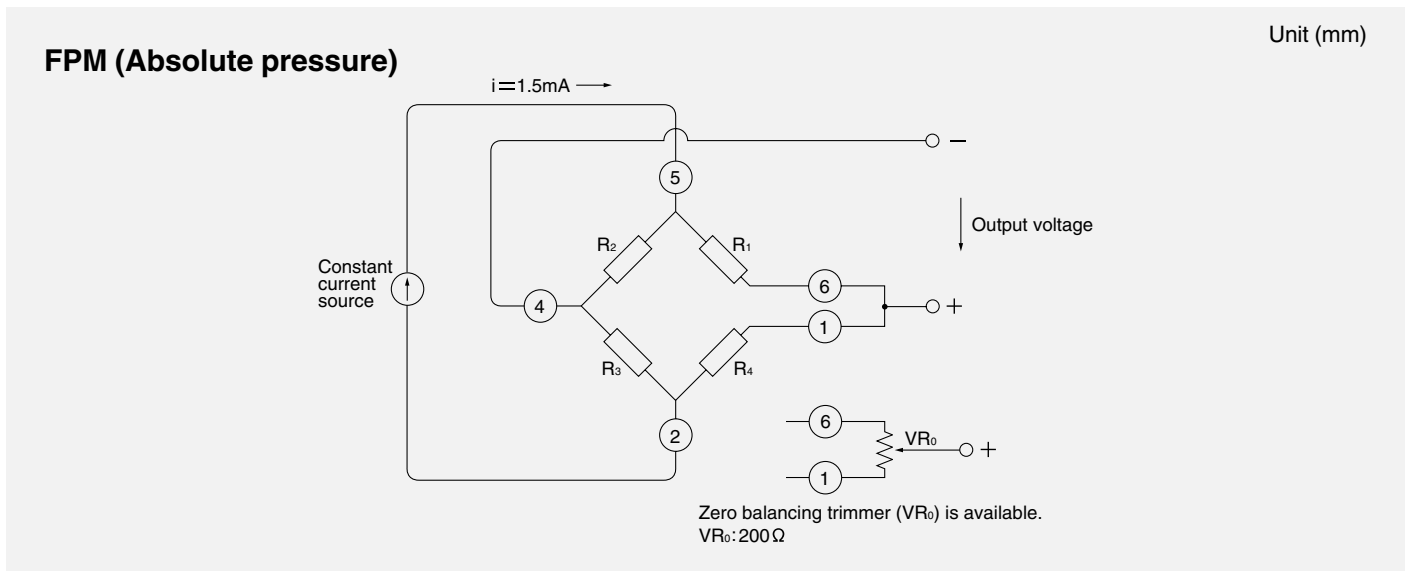

Note ; Please read instruction "Notes" before using the sensor.
 Fujikura reserves the right to change specifications without notice.

Fujikura Ltd.

If you have any questions regarding technical issues or specifications, please contact us.
 Sensor Engineering Department 5-1 Kiba 1-chome, Koto-ku, Tokyo 135-8512, Japan
 Phone +81-(0)3-5606-1072 Fax. +81-(0)3-5606-1538
 E-mail : sensor@fujikura.co.jp