

## Features

- Very small surface mountable package, Easy to mount on PCB
- Vacuum pressure measurable
- Non-corrosive liquid measurable(FGMC-3, FGMC-6 available)

## Applications

- Industrial instrumentation
- Pressure switch, Pneumatic device
- Medical device
- Turbo boost pressure measurement for Automotive system

## Part number for ordering

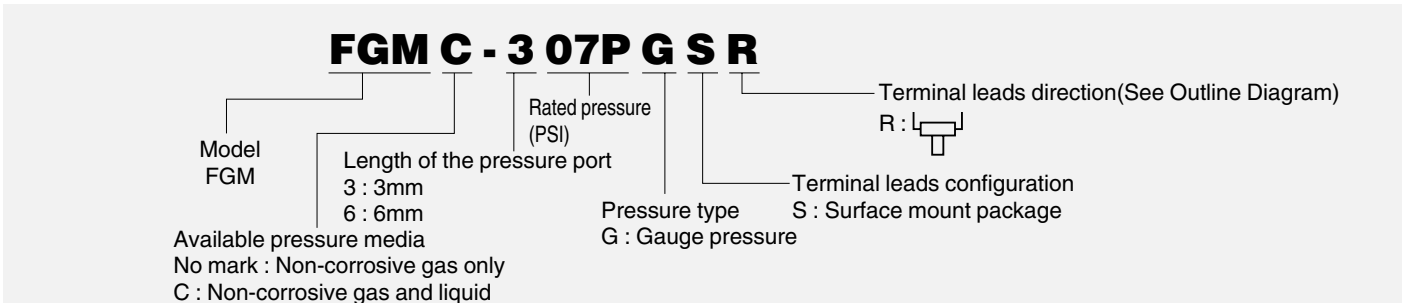

Pressure type	Gauge pressure	
	FGM-3	FGM-6
Model		
Package configuration	Surface mount package, 3mm pressure port	Surface mount package, 6mm pressure port

Measurable pressure range (kPa)	Part number for ordering			
-13.79~13.79	FGM-302PGSR	FGMC-302PGSR	FGM-602PGSR	FGMC-602PGSR
-34.47~34.47	FGM-305PGSR	FGMC-305PGSR	FGM-605PGSR	FGMC-605PGSR
-48.26~48.26	FGM-307PGSR	FGMC-307PGSR	FGM-607PGSR	FGMC-607PGSR
-98.07~103.4	FGM-315PGSR	FGMC-315PGSR	FGM-615PGSR	FGMC-615PGSR
-98.07~206.8	FGM-330PGSR	FGMC-330PGSR	FGM-630PGSR	FGMC-630PGSR
-98.07~344.7	FGM-350PGSR	FGMC-350PGSR	FGM-650PGSR	FGMC-650PGSR
-98.07~482.6	FGM-370PGSR	FGMC-370PGSR	FGM-670PGSR	FGMC-670PGSR
-98.07~827.4	FGM-3120PGSR	FGMC-3120PGSR	FGM-6120PGSR	FGMC-6120PGSR

## Specifications

Model/Rated pressure	02PG	05PG	07PG	15PG	30PG	50PG	70PG	120PG	Unit	
<b>Recommended operating conditions</b>										
Pressure type	Gauge pressure								—	
Rated pressure	13.79	34.47	48.26	103.4	206.8	344.7	482.6	827.4	kPa	
	0.141	0.352	0.492	1.055	2.109	3.516	4.922	8.437	kg/cm <sup>2</sup>	
Measurable pressure range	-13.79 ~13.79	-34.47 ~34.47	-48.26 ~48.26	-98.07 ~103.4	-98.07 ~206.8	-98.07 ~344.7	-98.07 ~482.6	-98.07 ~827.4	kPa	
Pressure media ※	FGM : Non-corrosive gas only, FGMC : Non-corrosive gas and liquid								—	
Excitation current (Constant)	1.5								mADC	
Absolute maximum rating										
Maximum load pressure	Twice of rated pressure								1.5times of rated pressure	—
Maximum excitation current	3								mADC	
Operating temperature	-20~100								°C	
Storage temperature	-40~120								°C	
Operating humidity	30~80 (No dew condensation)								%RH	
<b>Electric performances/characteristics (Excitation current I=1.5mA constant, Ambient temperature Ta=25°C)</b>										
Full scale span voltage	60~140								mV	
Offset voltage	±20								mV	
Bridge impedance	4000~6000								Ω	
Mechanical response time	2 (For the reference)								msec	
Accuracy	Temperature sensitivity of offset (TSO)	±5								%FS/0~50°C
	Temperature coefficient of sensitivity (TCS)	2.5								%FS/0~50°C
	Linearity	±0.5			±0.3		±0.5	±0.6	%FS	
	Pressure hysteresis	±0.4			±0.2		±0.4	±0.4	%FS	

※) Please consult us available liquid pressure media when you chose the C models.

Outline dimensions

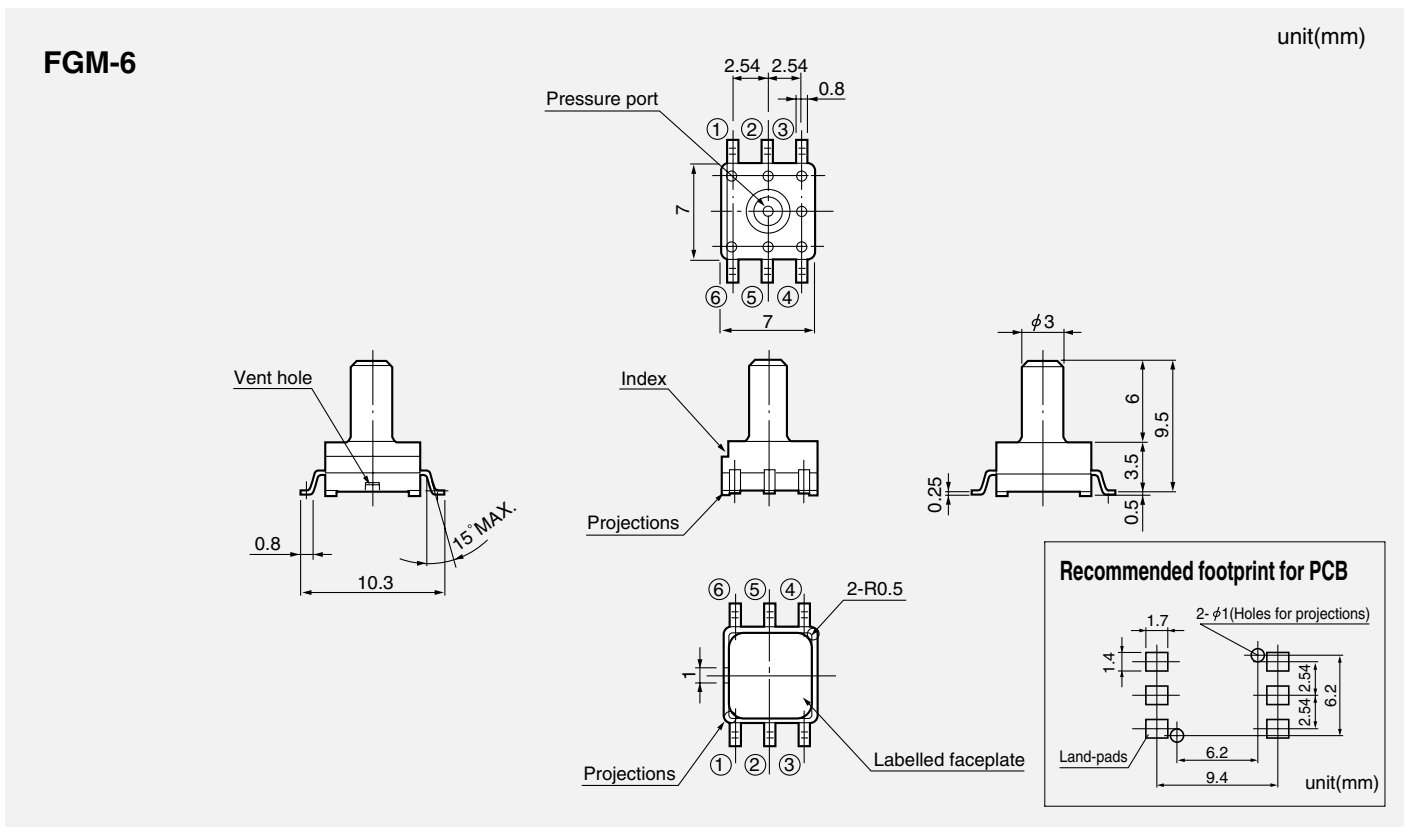
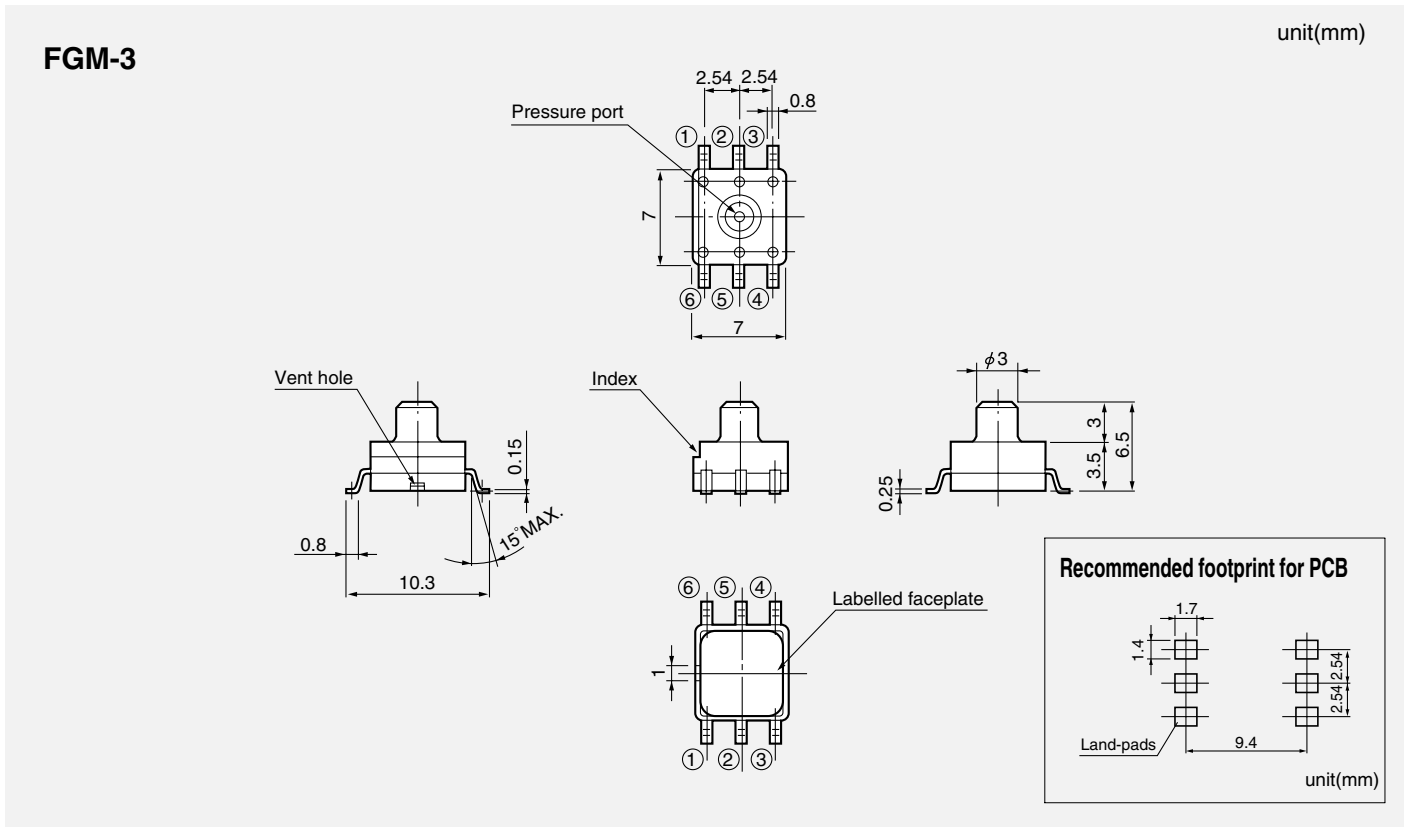

■ Connection diagram ■

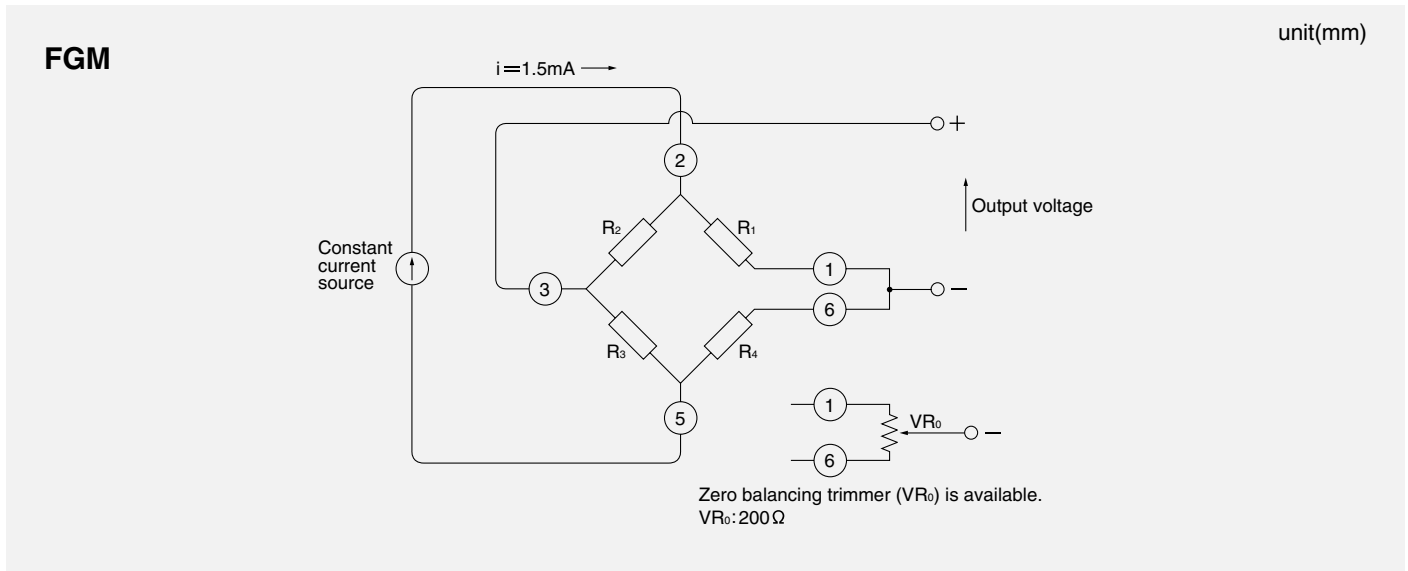

Note ; Please read instruction "Notes" before using the sensor.  
 Fujikura reserves the right to change specifications without notice.

**Fujikura Ltd.**

If you have any questions regarding technical issues or specifications, please contact us.  
 Sensor Engineering Department 5-1 Kiba 1-chome, Koto-ku, Tokyo 135-8512, Japan  
 Phone +81-(0)3-5606-1072 Fax. +81-(0)3-5606-1538  
 E-mail : sensor@fujikura.co.jp