

Tilt Sensors

SOLID STATE, LOW RANGE, ANALOG SERIES

- ▼ Small, Low-Cost, Rugged
- ▼ Vibration Resistant
- ▼ $\pm 20^\circ$ Range, 100 mV^o output
- ▼ Fully Conditioned Analog Outputs

Applications

- ▼ Scissor Lifts
- ▼ Static Platforms
- ▼ Alignment Systems
- ▼ Laser Leveling



CXTLA01, CXTLA02

The CXTLA single and dual axis analog tilt sensors offer resolution, accuracy, and fast response in an inexpensive, easy-to-use package. The CXTLA series design centers on a highly stable silicon micro-machined capacitive inclination sensor element. The CXTLA series is fully signal conditioned with high level analog output(s), and optional analog temperature signal.

Micro-machined devices, perfected in automotive safety applications, offer several distinct advantages over fluid, electrolytic, and pendulum-based sensors. Like other solid-state devices, they are more reliable than their mechanical counterparts. In a package smaller than many pendulum or fluid sensing elements, completely integrated electronics eliminate the need for external components.

Unlike other micro-machined devices, the CXTLA Series maintains its accuracy and stability over temperature: $< 25^\circ$ of arc over the range 0° to 70° C. The output can be user corrected for temperature with the T option, yielding accuracy to within $\pm 0.5^\circ$ over the angular range.

A typical configuration using CXTLA sensors is shown below. Each module is factory calibrated, tested and includes a calibration sheet. The module can be securely attached using screws or adhesive. The CXTLA is available in a standard nylon or high temperature aluminum package.

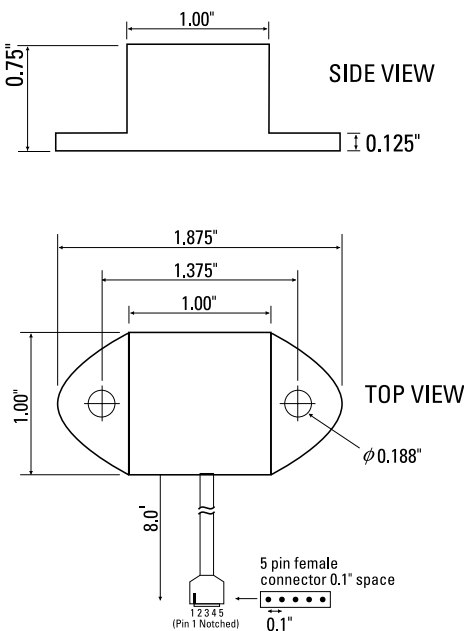

Micromachined Tilt Sensor Element

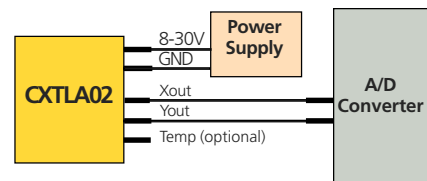

Typical CXTLA02 Configuration

tilt sensors

Specifications	CXTLA01	CXTLA02	Remarks
Performance			
Angular Range (°)	± 20	± 20	
Angular Resolution (° rms)	0.03	0.03	
Sensitivity - small angles (mV/°)	100 ± 10	100 ± 10	Actual value provided with Sensor
Sensitivity Drift (%/°C)	0.01	0.01	
Zero Angle Voltage (Volts)	2.5 ± 0.15	2.5 ± 0.15	Actual value provided with Sensor
Zero Angle Drift (mV/°C)	3	3	Typical
Zero Angle Drift (°/°C)	0.03	0.03	Typical
Non-Linearity (°)	< 0.4	< 0.4	Over ± 20° not including Arcsine Error
Bandwidth (Hz)	6	6	
Alignment (°)	± 1	± 1	Typical
Cross-axis Sensitivity (%)	< 5	< 5	Inclusive of alignment error
Environment			
Storage Temperature (°C)	-55 to +85	-55 to +85	Nylon Package
Operating Temperature (°C)	-40 to +85	-40 to +85	Nylon Package
Storage Temperature (°C)	-55 to +105	-55 to +105	-AL High Temperature Package
Operating Temperature (°C)	-40 to +105	-40 to +105	-AL High Temperature Package
Non-Operating Vibration (g rms)	10	10	20-2 kHz random
Shock (g)	2000	2000	1 ms, half sine
Electrical			
Supply Voltage (VDC)	8 - 30	8 - 30	Unregulated
Current (mA)	4	8	
Physical			
Size (Nylon Package)	.75 x 1.875 x 1.00" (1.91 x 4.763 x 2.54 cm)		
Size (Aluminum Package)	.95 x 2.00 x 1.20" (2.41 x 5.08 x 3.05 cm)		
Weight (Nylon Package)	1.38 oz (43 gm)		
Weight (Aluminum Package)	2.09 oz (65 gm)		

Specifications subject to change without notice

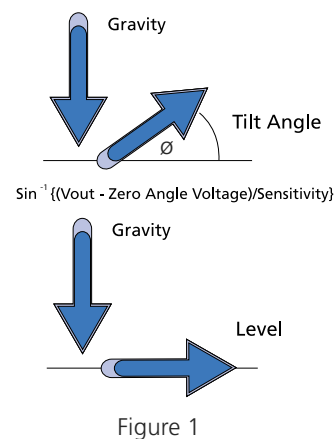

Principle of Operation

The CXTLA Series Tilt Sensors use a micro-machined acceleration sensing element with a DC response to measure inclination relative to gravity. The response of the tilt sensor depends on the magnitude of gravity parallel to the sensor element. The output of the tilt sensor will be an offset voltage plus the voltage response proportional to the amount of gravity measured by the sensor.

Using the CXTLA Sensor

The voltage response of the CXTLA is

proportional to the sine of the tilt angle.

Accurately measuring tilt angle involves solving the equation shown in the bottom of Figure 1. Clearly to solve this equation the Zero Angle Voltage and Sensitivity must be determined prior to use. Crossbow provides this information on a calibration sheet with its CXTLA products.

For angles less than 20°, the sine function can be approximated by a linear relationship between the Vout and the tilt angle in radians. Thus the equation for angle in degrees is:

$$180/\pi * [(Vout - Zero Angle Voltage)/Sensitivity]$$

The $180/\pi$ factor changes the angle from radians to degrees. When the tilt angle is less than 20°, the error from linear approximation will be less than 1%. This is convenient when you don't have or want the computing power to calculate an inverse sine function.

Pin	Color	Function
1	Red	Power
2	Black	Ground
3	White	Pitch
4	Yellow	Roll
5	Green	Temp

Pin Diagram

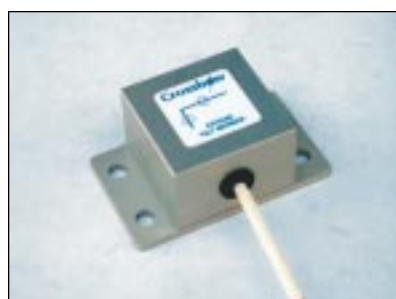

Optional Aluminum Package

Ordering Information

Model	Axes	Full Range	Resolution	
CXTLA01	X	± 20°	0.03°	
CXTLA02	X,Y	± 20°	0.03°	
OPTIONS				
-T	Temperature Sensor Internal			
-AL	High Temperature Aluminum Package			

CALL FACTORY FOR OTHER CONFIGURATIONS

If ordering options, please specify Model followed by the regulator option and then the package option, e.g.