

Magnetometers

MICRO-ORIENTATION SENSOR

- ▼ High Accuracy – Operates to 70°C
- ▼ Calculates and Outputs Roll, Pitch, Yaw Data
- ▼ Miniature Size:
0.80" x 0.80" x 4.6"
- ▼ Digital Serial Output
- ▼ Contains a 3-axis Magnetometer and a 3-axis Accelerometer

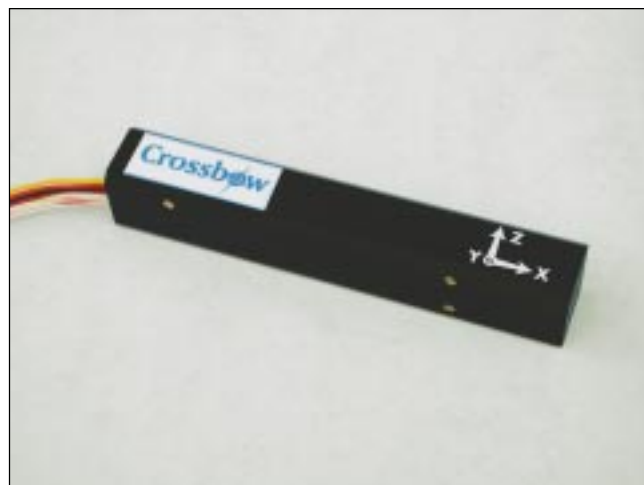

Applications

- ▼ Borehole Logging
- ▼ Buoy Orientation
- ▼ Magnetic Compassing
- ▼ Towed Sonar Arrays

CXM544

The CXM544 system contains a micro-machined 3-axis accelerometer and a high accuracy 3-axis fluxgate magnetometer. These sensors are sampled by an internal A/D converter and microprocessor subsystem that outputs 16-bit digital data representing the magnetometer and accelerometer readings and the calculated roll, pitch and azimuth orientation angles of the CXM544 system.

All of the system electronics, including the accelerometer and magnetometer sensors are mounted in a miniature rectangular package of dimensions 0.80" x 0.80" x 4.6". Input power is user selectable from either +5 VDC or +7 to +12 VDC.

The CXM544 communicates through a bidirectional serial data link, which can be selected from either TTL compatible or RS-232 compatible protocols, at a user programmable data transfer rate of up to 9600 baud. The CXM544 uses an ASCII command set, but the user can enable a high-speed binary communications protocol.

The CXM544 scale factors, zero-bias factors and alignment angles are measured by placing the system into precision rotational and magnetic field-applying fixtures. Scale and offset calibration factors are calibrated over the 0 to 70°C temperature range. The integral microprocessor uses this system calibration data (stored in EEROM) to correct for alignment, scale and offset factors at any given temperature.

The magnetometer noise level is 5×10^{-6} Gauss and the accelerometer noise level is 2×10^{-4} g. The maximum data throughput is approximately 3 readings/sec if all 6 outputs are transmitted. When viewed as a roll, pitch, and yaw sensor, the temperature compensated CXM544 system has an overall accuracy of $\pm 0.5^\circ$ for roll and pitch and $\pm 1.5^\circ$ for azimuth.

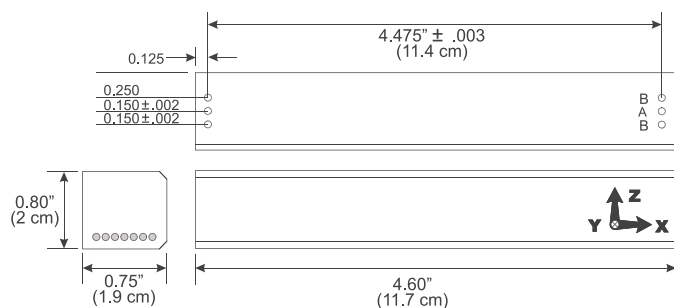

Specifications	CXM544
Performance	
Angular Accuracy	
Roll and Pitch (°)	± 0.5
Azimuth (°)	± 1.5
Noise level Magnetometer (Gauss)	5 x 10 ⁻⁶
Noise level Accelerometer (g)	2 x 10 ⁻⁴
Linearity (% FS)	± 0.1
Axis Alignment (°)	± 0.2
Alignment of Axes w/ Package Reference Frame (°)	± 0.2
Serial Output	RS-232 or TTL
Electrical	
Power	+5V @ 55 mA or +7 to +12V @ 65 mA
Physical	
Size	0.80" x 0.75" x 4.6" (2 x 1.9 x 11.68 cm)
Weight	1.61 oz (50 gm)
Leads	Flying leads 6" (15.24 cm) long

Specifications subject to change without notice

Wire Color	Function
Red	+7 to +12 VDC
Black	Ground
White/Red	+5 VDC
Orange	RS-232 serial in
Yellow	RS-232 serial out
White/Orange	TTL serial in
White/Yellow	TTL serial out

Pin Diagram



magnetometers

Ordering Information

Model	Description
CXM544	Digital 3-axis Magnetometer