

Magnetometers

HIGH-SPEED DIGITAL 3-AXIS FLUXGATE SENSOR

- ▼ $\pm 100 \mu\text{T}$ (± 1 Gauss) Full Scale Output
- ▼ Programmable Sample Rate 1/s to 250/s
- ▼ ± 3 nT of Noise

Applications

- ▼ High-speed Magnetic Sensing
- ▼ Magnetic Anomaly Detection
- ▼ Guidance/Compassing
- ▼ Laboratory Measurements
- ▼ Magnetic Field Mapping
- ▼ Materials Testing



CXM539

The CXM539 is the first high-speed, digital output, 3-axis fluxgate magnetometer to be commercially available. The system can convert and transmit over its serial port all three axes outputs at a rate up to 250 samples per second at 38400 baud. Sample rates and baud rates are user-programmable.

The CXM539 uses 3 separate 16-bit sigma delta converters to achieve high throughput. The scale factor is set so that a full-scale input of 10^{-4}T (1 Gauss) represents 32,768 counts on the system A/D. The least count represents about 3 nT. System noise is 1 - 2 counts.

The CXM539 system is ideally suited to situations where high-speed magnetic data must be acquired and analyzed. In the past, such systems have normally used a combination of an analog output fluxgate and an A/D board in a PC. The CXM539 simplifies and reduces the cost of the magnetic data acquisition system by eliminating the cumbersome A/D board.

The CXM539 can be used in either a command mode or auto send mode. In the command mode, the CXM539 responds to commands to transmit data issued by an external computer. In the auto send mode, the CXM539 commences sending data as soon as power is applied to the unit.

The CXM539 can be supplied with an optional connection cable and breakout box, which allows easy powering and connection to an external computer. A Windows™ compatible configuration and data acquisition and display program is supplied with the CXM539. This program enables the user to acquire and graphically display data as well as configure the CXM539 send rate, baud rate, output format, and other features.

In addition to the standard RS-232 interface, which is normally employed when communicating with a PC, the CXM539 is also equipped with a TTL interface for communication with a microprocessor.

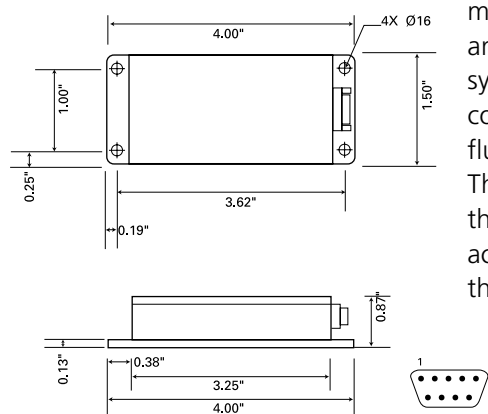

Specifications	CXM539
Performance	
Accuracy (μ T)	± 0.1 (± 1 mGauss)
Noise (nT)	± 3 (± 0.03 mGauss)
Range (μ T)	± 100 (± 1 g)
Scale Stability (% FS/ $^{\circ}$ C)	± 0.05
Initial Offset (nT)	$<\pm 200$ (± 2 mGauss)
Offset vs. Temperature (nT/ $^{\circ}$ C)	< 5 (< 0.05 mGauss)
Orthogonality of Axes ($^{\circ}$)	Better than ± 0.5
Axes Alignment with Package ($^{\circ}$)	Better than ± 0.5
Linearity (% full scale)	± 0.1
Maximum Data Transfer	250 3-axis samples/sec @38,400 baud
A/D	3 16-bit Sigma Delta Converters
Data Levels	RS-232 and TTL
Environment	
Operating Temperature ($^{\circ}$ C)	- 20 to + 70
Electrical	
Power Input	100 mA@ + 7.5 to + 15 VDC
Baud Rate (User Selectable)	300 to 72800
Physical	
Size	1.60" x 4.08" x 1.125" (4 cm x 10.4 cm x 2.9 cm)
Connector	9-pin non-magnetic "D"

Specifications subject to change without notice



magnetometers



Pin	Function
2	RS 232 out
3	RS 232 in
5	Ground
6	TTL serial out
7	TTL serial in
8	Configure
9	+7.5 to +15V DC

Pin Diagram

Ordering Information

Model	Description
CXM539	High-speed Digital 3-axis Fluxgate Sensor