

Magnetometers

PC BOARD LEVEL 3-AXIS FLUXGATE MAGNETOMETER

- ▼ Complete 3-axis System
- ▼ Measures Fields up to ± 0.7 Gauss ($\pm 100 \mu\text{T}$)
- ▼ Low Noise Level ± 6 nT
- ▼ Low Cost PC Board Configuration

Applications

- ▼ OEM Magnetic Field Measuring
- ▼ Fluxgate Compass System
- ▼ Magnetic Anomaly Detection

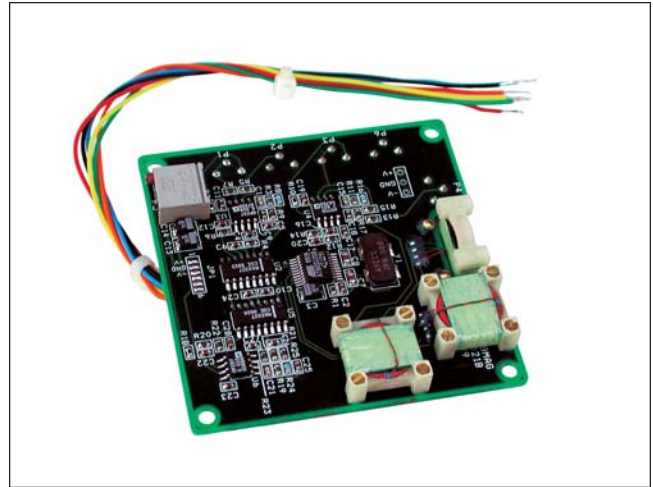

CXM113

The CXM113 is a complete 3-axis fluxgate magnetometer system packaged on a PC board of dimensions 2.5" x 2.5" x 0.75" (6.4cm x 6.4cm x 1.9cm). The system operates from an input voltage of ± 5 VDC. Current consumption is 28 mA @ +5 V and 7 mA @ -5 V. The system is connected by 6" long flying leads.

The CXM113 provides 3 analog output voltages proportional to the magnetic field magnitude measured in three orthogonal directions. The full-scale output is ± 2.8 volts; representing a magnetic field of ± 0.7 Gauss. Output scale factor is adjusted to an accuracy of 1%. The system noise level is ± 6 nT. As a magnetic compass, the CXM113 can provide direction accuracy better than 0.1° .

For magnetic anomaly detection applications, the low noise level of the CXM113 allows very small magnetic signatures to be measured. This enables signal detection at a large distance from the anomaly being measured. Range to the anomaly can be measured by using several CXM113s to record both field magnitude and field gradient. Range is proportional to the quotient of these quantities.

A calibration sheet is provided with each unit giving data on zeros, scale factors, and orthogonality constants for each axis. This data enables an external correction of the output voltages to increase overall accuracy.

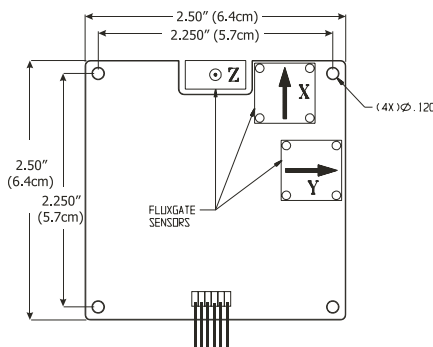

Specifications	CXM113
Performance	
Range (Gauss)	± 0.7
Noise Level (nT)	± 6 (± 0.06 mGauss)
Frequency Response (Hz)	DC to 400 (-3 dB)
Non-Linearity (% FS)	± 2.0
Zero Drift with Temperature (mGauss/°C)	< 0.1
Scale Factor Drift with Temperature (% FS/°C)	< 0.1
Sensitivity (V/Gauss)	4.00
Othogonality of Axes (°)	± 2.0
Alignment of Axes w/ Package Reference Frame (°)	± 2.0
Environment	
Operating Temperature (° C)	- 20 to + 70
Electrical	
Power	+ 5V @ 28 mA and -5 V @ 7 mA
Physical	
Size	2.5" x 2.5" x .75" (6.4 cm x 6.4 cm x 1.9 cm)
Weight	0.975 oz (30 gm)
Leads	Flying leads 6" (15.24 cm) long

Specifications subject to change without notice

Wire Color	Function
Red	+5 VDC
Black	Ground
Blue	-5 VDC
Orange	X-axis output
Yellow	Y-axis output
Green	Z-axis output

Pin Diagram

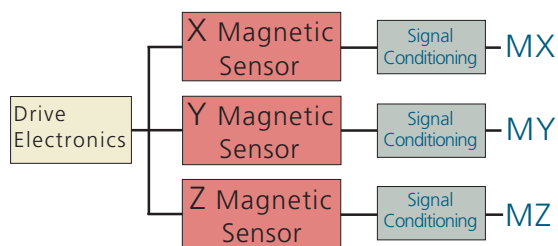

Analog Output 3-Axis Magnetometer Board

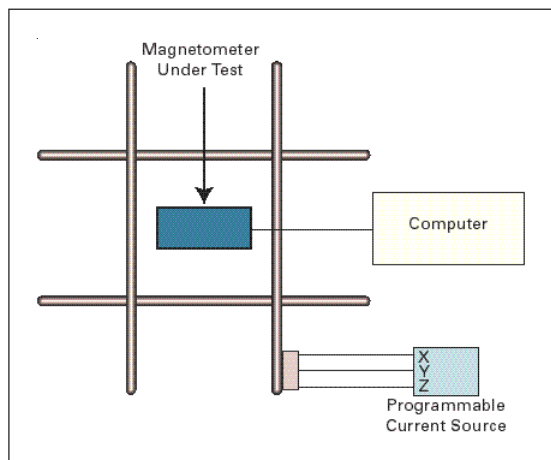

The CXM113 is Calibrated Using a Precision 3-axis Helmholtz Coil



magnetometers

Ordering Information

Model	Description
CXM113	PC Board Level, 3-axis Fluxgate Magnetometer