



Part Number	Relay Description
C45	Solid-State Relay, Terminals for Through Hole Mount
SC45	Solid-State Relay, Terminals for Surface Mount

ELECTRICAL SPECIFICATIONS
(25°C UNLESS OTHERWISE SPECIFIED)

INPUT (CONTROL) SPECIFICATIONS

Parameter	Part Number	Min	Max	Units
Control Voltage Range (See Figure 1 and Note 1)	C45-13,-23	3.5	7.0	Vdc
Control Current (See Figure 2 and Note 1)	C45-11,-21	5.0	50.0	
	C45-12,-22	10.0	50.0	mA
	C45-13,-23	10.0	25.0	
Must Turn-On Current	C45-11,-21	5.0		mA
	C45-12,-22	10.0		
Must Turn-On Voltage	C45-13,-23	3.5		Vdc
Must Turn-Off Voltage		0.5	Vdc	
Must Turn-Off Current	C45-11,-21			
	C45-12,-22		0.1	mA
Reverse Voltage Protection			-7.0	Vdc

OUTPUT (LOAD) SPECIFICATIONS

Parameter	Part Number	Min	Max	Units
Load Voltage Range			280	Vrms
Output Current Rating (See Figure 4)		0.01	1.0	Arms
Frequency Range		47	440	Hz
Over Voltage Rating	C45-11,-12,-13		400	Vpeak
	C45-21,-22,-23		500	
On-State Voltage Drop at Rated Current			1.5	Vrms
Zero Voltage Turn-On			15	Vpeak
Surge Current Rating (See Figure 3, Notes 3 and 4)			8.0	Apeak
Turn-On Time			1/2	Cycle
Turn-Off Time			1.0	Cycle
Leakage Current (Off-State)			1.0	mArms
Off-State dV/dt (Typical)			200	V/μs
Isolation (Input to Output)		10 ⁹		Ohms
Dielectric Strength (Input to Output)		4000		Vac
Capacitance (Input to Output)			10	pF
Junction Temperature (T _j)			150	°C

FEATURES/BENEFITS

- Switches 400 Hz: Required in aircraft and military applications
- Zero Voltage Turn-On: Minimum switching transient noise and extremely low EMI
- Optical Isolation: Isolates control circuits from transients.
- Floating Output: Eliminates ground loops and signal ground noise.
- Low Off State Leakage: For high off-state impedance
- Switches High Voltages: To 280 Vrms.
- Switches High Currents: To 1.0 Arms
- High Noise Immunity: Controls signals isolated from switching noise.
- High Dielectric Strength: For safety and protection of signal level circuits.

DESCRIPTION

The C45 Series employs back-to-back photo SCRs and a patented zero crossing switching circuit. The tight zero switch window ensures reliable transient free switching of AC loads and very low noise and EMI generation. Optical isolation of control circuits from load switching prevents noise coupling into signal lines and signal power and ground distribution systems. This series of solid-state relays will switch from 0.01 to 1.0 Arms at 280 Vrms. The C45 is packaged in a low profile 16 pin Dual-In-Line package with either surface SC45-XX or through-hole C45-XX pin configurations for optimum printed circuit card mounting and minimum space utilization.

CHARACTERISTIC CURVES

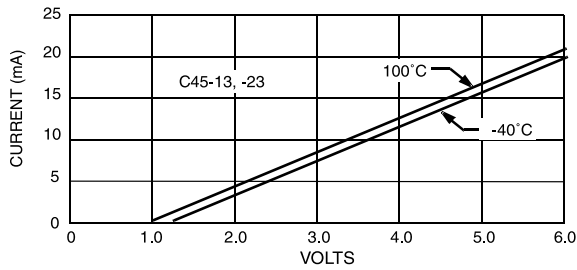

INPUT CURRENT VS CONTROL VOLTAGE
FIGURE 1

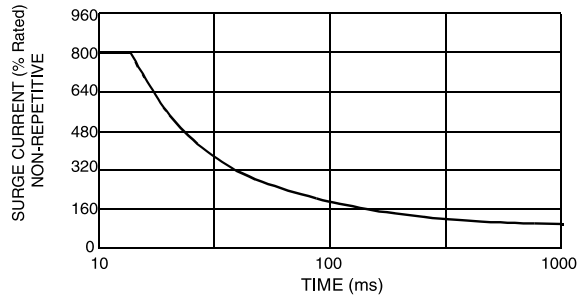

SURGE CURRENT VS DURATION
FIGURE 3

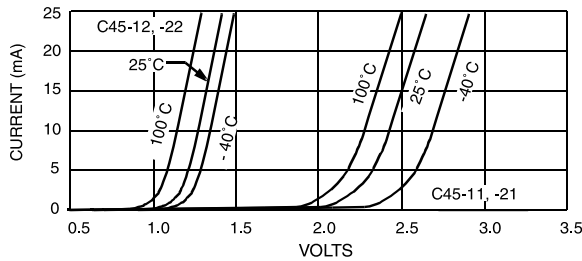

INPUT CURRENT VS CONTROL VOLTAGE
FIGURE 2

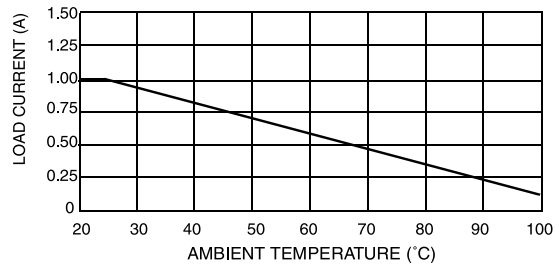

LOAD CURRENT VS TEMPERATURE
FIGURE 4

MECHANICAL SPECIFICATIONS

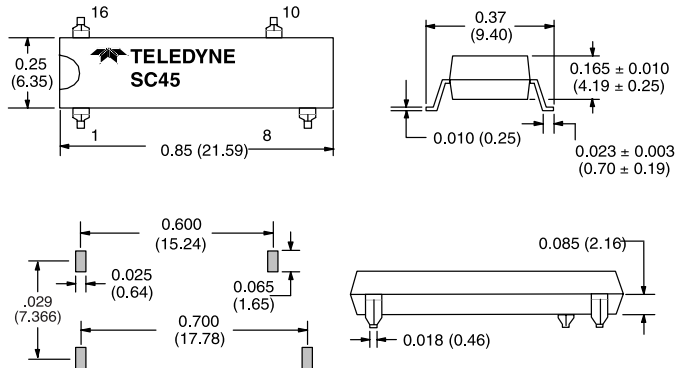

SURFACE MOUNT LAND PATTERN

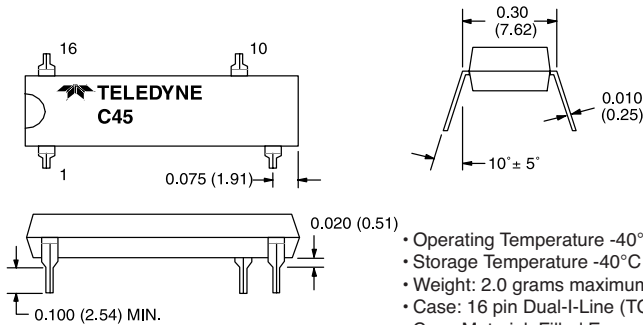

- Operating Temperature -40°C to 100°C
- Storage Temperature -40°C to 100°C
- Weight: 2.0 grams maximum
- Case: 16 pin Dual-In-Line (TO-116)
- Case Material: Filled Epoxy, self extinguishing
- Solderability (10 sec) 235°C

DIMENSIONS ARE IN INCHES (MILLIMETERS)
Tolerances ± 0.015 (0.38) unless specified.

TYPICAL C45 INTERFACE

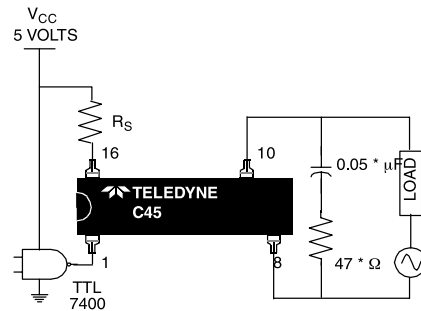

R_S may be required to prevent exceeding maximum input current.

* OPTIONAL SNUBBER NETWORK FOR TRANSIENT VOLTAGE AND dV/dt SUPPRESSION - SEE NOTE 3

NOTES:

1. Operation at load frequencies above 70 Hz requires increased input signal. The minimum input voltage is 4.5 Vdc for C45-11, -21 and the minimum input current is 15 mA for the C45-12, -22.
2. Minimum Load Power Factor = 0.4.
3. RC snubber is recommended but not required.
4. Non-repetitive 16 ms maximum.