

# TELEDYNE RELAYS

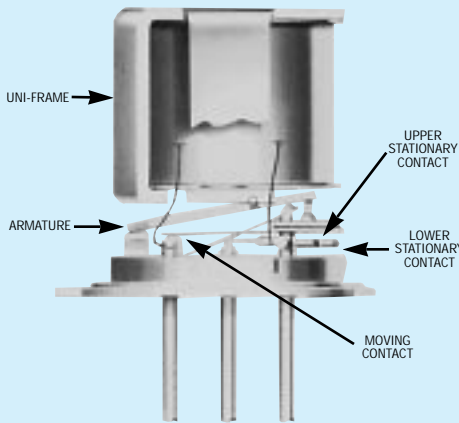
## ESTABLISHED RELIABILITY TO-5 RELAY SENSITIVE SPDT

SERIES  
**431**



SERIES DESIGNATION	RELAY TYPE
431	SPDT basic relay
431D	SPDT relay with internal diode for coil suppression
431DD	SPDT relay with internal diodes for coil transient suppression and polarity reversal protection
431T	SPDT relay with internal transistor driver and coil transient suppression diode

### INTERNAL CONSTRUCTION



### DESCRIPTION

The TO-5 relay, originally conceived and developed by Teledyne, has become one of the industry standards for low level switching from dry circuit to 1 ampere. Designed expressly for high density PC Board mounting, its small size, low coil power dissipation make the TO-5 relay one of the most versatile ultraminiature relays available.

The following unique construction features and manufacturing techniques provide excellent resistance to environmental extremes and overall high reliability:

- All welded construction.
- Unique uni-frame design providing high magnetic efficiency and mechanical rigidity.
- High force/mass ratios for resistance to shock and vibration.
- Advanced cleaning techniques provide maximum assurance of internal cleanliness.
- Precious metal alloy contact material with gold plating assures excellent high current and dry circuit switching capabilities.

The 431D and 431DD Series utilizes internal discrete silicon diodes for coil suppression and polarity reversal protection. The hybrid 431T features an internal silicon suppression diode and transistor driver. This hybrid package reduces PC board floor space by reducing the number of external components needed to drive the relay.

By virtue of its inherently low intercontact capacitance and contact circuit losses, the TO-5 relay has shown itself to be an excellent ultraminiature RF switch for frequency ranges well into the UHF spectrum. A typical RF application for the TO-5 relay is in hand held radio transceivers, wherein the combined features of good RF performance, small size, low coil power dissipation and high reliability make it a preferred method of T-R switching (see Figure 1).

ENVIRONMENTAL AND PHYSICAL SPECIFICATIONS	
Temperature (Ambient)	-65°C to +125°C
Vibration	30 g's to 3000 Hz (Note 1)
Shock	75 g's for 6 msec. (Note 1) half-sine
Acceleration	50 g's (Note 1)
Enclosure	All welded, hermetically sealed
Weight	0.109 oz (3.09 gms.) max.

**SERIES 431**

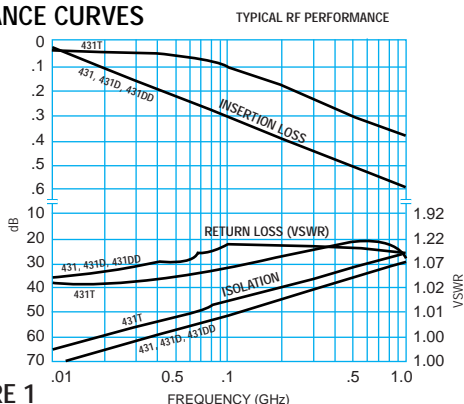
**GENERAL ELECTRICAL SPECIFICATIONS** (-65°C to +125°C unless otherwise noted) (Notes 2 & 8)

Contact Arrangement	1 Form C (SPDT)	
Rated Duty	Continuous	
Contact Resistance	0.1 ohm max. before life; 0.2 ohm max. after life at 1A/28VDC, (measured 1/8" from header)	
Contact Load Rating (DC) (See Fig. 2 for other DC resistive voltage/current ratings)	Resistive: 1 Amp/28VDC Inductive: 200 mA/28VDC (320 mH) Lamp: 100 mA/28VDC Low Level: 10 to 50 µA/10 to 50 mV	
Contact Load Ratings (AC)	Resistive: 250 mA/115VAC, 60 and 400Hz (Case not grounded) 100 mA/115VAC, 60 and 400Hz (Case grounded)	
Contact Life Ratings	10,000,000 cycles (typical) at low level 1,000,000 cycles (typical) at 0.5A/28VDC resistive 100,000 cycles min. at all other loads specified above	
Contact Overload Rating	2A/28VDC Resistive (100 cycles min.)	
Contact Carry Rating	Contact factory	
Coil Operating Power	150 milliwatts typical at nominal rated voltage @ 25°C	
Operate Time	431, 431D, 431DD Series: 4.0 msec max. at nominal rated coil voltage	431T: 3.5 msec (Note 7)
Release Time	431 Series: 2.5 msec max.	431D, 431DD, 431T Series: 7.5 msec max.
Contact Bounce	1.5 msec max.	
Intercontact Capacitance	0.4 pf typical	
Insulation Resistance	10,000 megohms min. between mutually isolated terminals	
Dielectric Strength	Atmospheric pressure: 500 VRMS/60 Hz	70,000 ft.: 300 VRMS/60Hz (431T: 125 VRMS/60 Hz)
Negative Coil Transient (VDC) (431D, 431DD, 431T)	1.0 max.	
Diode P.I.V. (VDC) (431D, 431DD, 431T)	100 min.	
431T Transistor Characteristics	Base Turn Off Voltage (VDC)	0.3 min.
	Emitter-base breakdown Voltage (BV <sub>EB0</sub> ) (@ 25°C) (VDC)	6.0 min.
	Collector-base breakdown Voltage (BV <sub>CB0</sub> ) (@ 25°C & I <sub>c</sub> = 100 µA) (VDC)	75 min.

**DETAILED ELECTRICAL SPECIFICATIONS** (-65°C to +125°C unless otherwise noted) (Note 8)

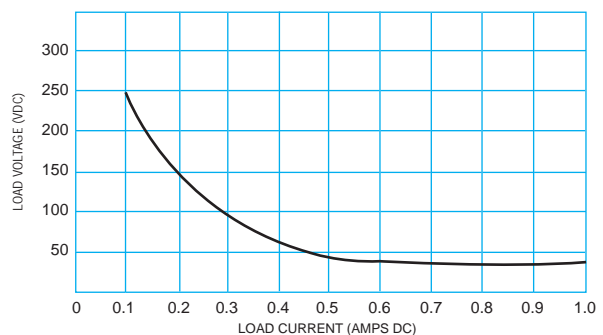
BASE PART NUMBERS (See Note 11 for full P/N Example)	➔	431-5	431-6	431-9	431-12	431-18	431-26	
		431D-5 431DD-5 431T-5	431D-6 431DD-6 431T-6	431D-9 431DD-9 431T-9	431D-12 431DD-12 431T-12	431D-18 431DD-18 431T-18	431D-26 431DD-26 431T-26	
Coil Voltage (VDC)	Nom.	5.0	6.0	9.0	12.0	18.0	26.5	
	Max.	8.0	11.0	16.0	22.0	33.0	45.0	
Coil Resistance (Ohms ±10% @ 25°C)	431, 431D, 431T (Note 3)	125	255	630	1025	2300	4000	
	431DD (Note 3)	100	200	630	1025	2300	4000	
Coil Current (mADC @ 25°C) (431DD Series)	Min.	36.3	22.7	11.5	9.7	6.7	5.7	
	Max.	50.0	30.6	15.0	12.5	8.5	7.2	
Coil Current (mADC @ 25°C) (431T Series)	(Note 7) Min.	34.7	21.2	11.8	10.1	6.7	5.7	
	Max.	47.8	27.7	16.8	13.6	9.1	7.7	
Pick-up Voltage (VDC, Max.)	431, 431D	3.7	4.5	6.8	9.0	13.5	18.0	
	431DD	4.5	5.5	7.8	10.0	14.5	19.0	
	431T (Note 7)	3.6	4.8	7.8	10.0	14.5	19.0	
Base Current to Turn On (mADC, Max.) (431T Series) (Note 7)		1.2	0.78	0.48	0.39	0.26	0.20	
Drop-out Voltage (VDC)	431, 431D, 431T (Note 7)	Min.	0.15	0.18	0.35	0.41	0.58	0.89
		Max.	2.0	2.8	4.2	5.6	8.4	10.4
	431DD	Min.	0.15	0.18	0.35	0.40	0.58	0.89
		Max.	2.4	2.8	4.2	5.6	8.4	10.4

**PERFORMANCE CURVES**  
(NOTE 2)

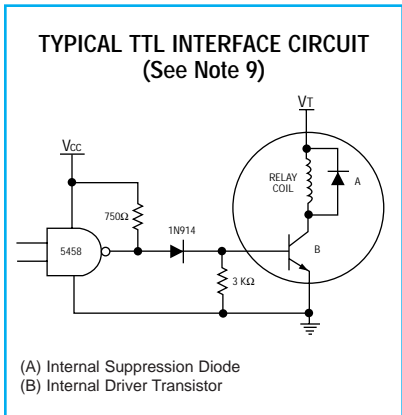
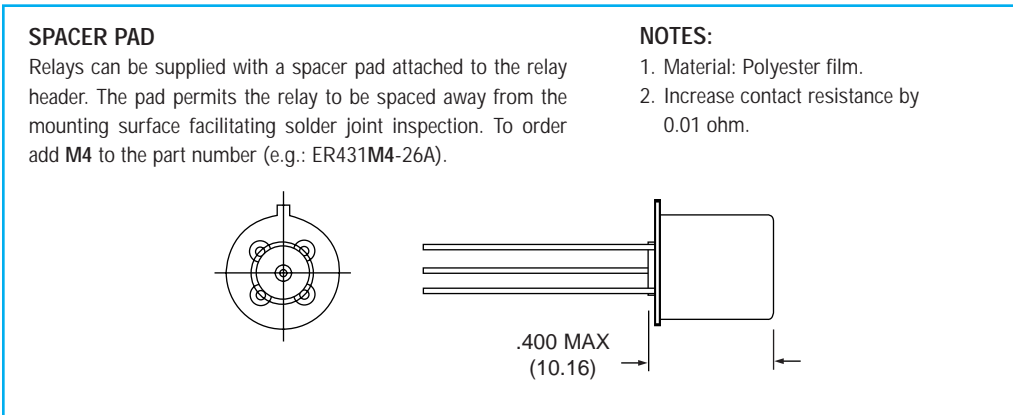
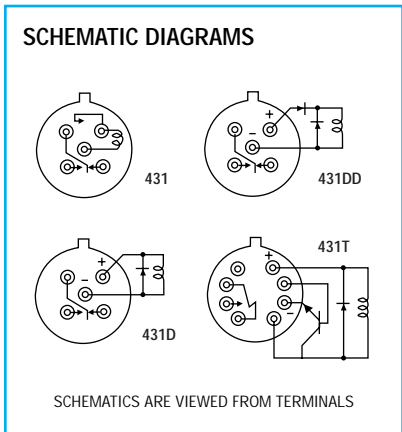
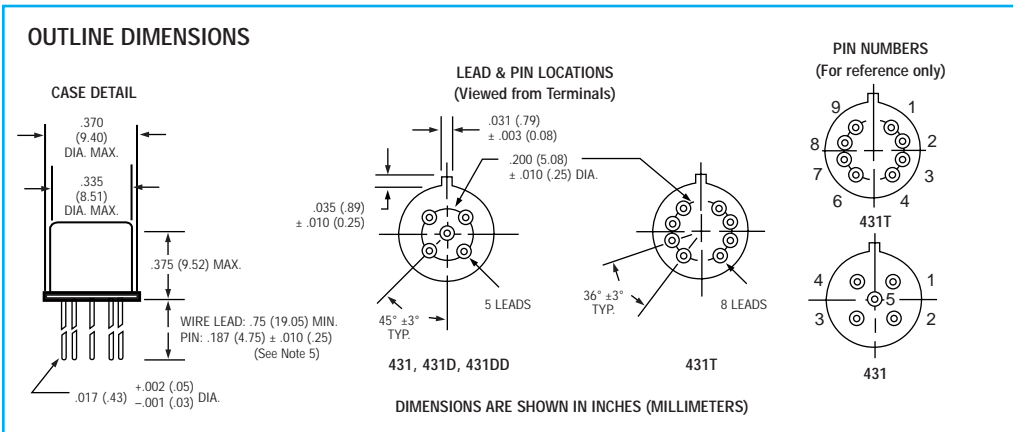


**FIGURE 1**

TYPICAL DC CONTACT RATING (RESISTIVE)



**FIGURE 2**



**NOTES:**

1. Relays contacts will exhibit no chatter in excess of 10 μsec or transfer in excess of 1 μsec.
2. "Typical" characteristics are based on available data and are best estimates. No on-going verification tests are performed.
3. For reference only. Coil resistance not directly measurable at relays terminals due to internal series semiconductor. 431DD and 431T only.
4. Screened HI-REL versions available. Contact factory.
5. Unless otherwise specified, relays will be supplied with leads as follows: Length will be standard 0.75" (19.05) minimum and will be either gold plated or solder coated. Contact your local representative for ordering information.
6. The slash and characters appearing after the slash are not marked on the relay.
7. Limit Base Emitter current to 15 mADC.
8. Unless otherwise specified, parameters are initial values.
9. Circuit is typical for all 431T Series. Values shown are for the 5 volt series and apply over the full operating temperature range.

10.

RELIABILITY LEVEL	FAILURE RATE %/10,000 CYCLES
A	1.5
B	0.75

