

# TELEDYNE RELAYS

## MAGNETIC LATCHING ESTABLISHED RELIABILITY TO-5 RELAYS DPDT

SERIES  
**420/422**



SERIES DESIGNATION	RELAY TYPE
420/422	DPDT basic relay
420D/422D	DPDT relay with internal diode for coil transient suppression
420DD/422DD	DPDT relay with internal diodes for coil transient suppression and polarity reversal protection

### DESCRIPTION

The TO-5 relay, originally conceived and developed by Teledyne, has become one of the industry standards for low level switching from dry circuit to 1 ampere. Designed expressly for high density PC Board mounting, its small size and low coil power dissipation make the TO-5 relay one of the most versatile ultraminiature relays available.

The following unique construction features and manufacturing techniques provide excellent resistance to environmental extremes and overall high reliability:

- All welded construction.
- Unique uni-frame design providing high magnetic efficiency and mechanical rigidity.
- High force/mass ratios for resistance to shock and vibration.
- Advanced cleaning techniques provide maximum assurance of internal cleanliness.
- Precious metal alloy contacts material with gold plating assures excellent high current and dry circuit switching capabilities.

The 420D/422D and 420DD/422DD Series utilizes discrete diodes for coil suppression and polarity reversal protection.

By virtue of its inherently low intercontact capacitance and contact circuit losses, the TO-5 relay has shown itself to be an excellent ultraminiature RF switch for frequency ranges well into the UHF spectrum. A typical RF application for the TO-5 relay is in hand held radio receivers, wherein the combined features of good RF performance, small size, low coil power dissipation and high reliability make it a preferred method of transmit-receive switching (see Figure 1).

The 420/422 Series magnetic latching relays are ideally suited for applications where power dissipation must be minimized. The relays can be operated with a short duration pulse. After contacts have transferred, no external holding power is required.

The magnetic latching feature of the 420/422 Series provides a "memory" capability, since the relays will not reset upon removal of power.

### PRINCIPLE OF OPERATION

Energizing Coil B produces a magnetic field opposing the holding flux of the permanent magnet in Circuit B. As this net holding force decreases, the attractive force in the air gap of Circuit A, which also results from the flux of the permanent magnet, becomes great enough to break the armature free of Core B, and snap it into a closed position against Core A. The armature then remains in this position upon removal of power from Coil B, but will snap back into position B upon energizing Coil A. Since operation depends upon cancellation of a magnetic field, it is necessary to apply the correct polarity to the relay coils as indicated on the relay schematic.

When latching relays are installed in equipment, the latch and reset coils should not be pulsed simultaneously. Coils should not be pulsed with less than the nominal coil voltage and the pulse width should be a minimum of three times the specified operate time of the relay. If these conditions are not followed, it is possible for the relay to be in the magnetic neutral position.

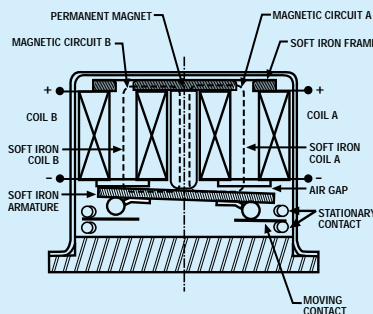

ENVIRONMENTAL AND PHYSICAL SPECIFICATIONS	
Temperature (Ambient)	-65°C to + 125°C
Vibration	30 g's to 3000 Hz (Note 1)
Shock	100 g's for 6 msec. (Note 1) half-sine
Acceleration	50 g's (Note 1)
Enclosure	All welded, hermetically sealed
Weight	0.10 oz (2.84 gms.) max.

**GENERAL ELECTRICAL SPECIFICATIONS** (-65°C to +125°C unless otherwise noted) (Notes 2 & 7)

<b>Contact Arrangement</b>		2 Form C (DPDT)
<b>Rated Duty</b>		Continuous
<b>Contact Resistance</b>		0.125 ohm max. before life; 0.225 ohm max. after life at 0.5A/28VDC, (measured 1/8" from header)
<b>Contact Load Rating (DC)</b> (See Fig. 2 for other DC resistive voltage/current ratings)		Resistive: 1.0 Amp/28VDC Inductive: 200 mA/28VDC (320 mH) Lamp: 100 mA/28VDC Low Level: 10 to 50 µA/10 to 50 mV
<b>Contact Load Ratings (AC)</b>		Resistive: 250 mA/115VAC, 60 and 400Hz (Case not grounded) 100 mA/115VAC, 60 and 400Hz (Case grounded)
<b>Contact Life Ratings</b>		10,000,000 cycles (typical) at low level 1,000,000 cycles (typical) at 0.5A/28VDC resistive 100,000 cycles min. at all other loads specified above
<b>Contact Overload Rating</b>		2A/28VDC Resistive (100 cycles min.)
<b>Contact Carry Rating</b>		Contact factory
<b>Coil Operating Power</b>		290 milliwatts typical at nominal rated voltage @ 25°C
<b>Operate Time</b>	420/422, 420D/422D	1.5 msec max. at nominal rated coil voltage
	420DD/422DD	2.0 msec max. at nominal rated coil voltage
<b>Contact Bounce</b>		2.0 msec max.
<b>Minimum Operate Pulse</b>		4.5 msec @ nominal voltage
<b>Intercontact Capacitance</b>		0.4 pf typical
<b>Insulation Resistance</b>		10,000 megohms min. between mutually isolated terminals
<b>Dielectric Strength</b>		Atmospheric pressure: 500 VRMS/60 Hz      70,000 ft.: 125 VRMS/60Hz
<b>Diode P.I.V.</b> (420D/422D, 420DD/422DD)		100 VDC min.
<b>Negative Coil Transient</b> (420D/422D, 420DD/422DD)		1.0 VDC max.

**DETAILED ELECTRICAL SPECIFICATIONS** (-65°C to +125°C unless otherwise noted) (Note 7)

BASE PART NUMBERS (See Note 9 for full P/N Example)	➔	420/422-5	420/422-6	420/422-9	420/422-12	420/422-18	420/422-26
		420D/422D-5 420DD/422DD-5	420D/422D-6 420DD/422DD-6	420D/422D-9 420DD/422DD-9	420D/422D-12 420DD/422DD-12	420D/422D-18 420DD/422DD-18	420D/422D-26 420DD/422DD-26
<b>Coil Voltage (VDC)</b>	Nom.	5.0	6.0	9.0	12.0	18.0	26.5
	Max.	6.0	8.0	12.0	16.0	24.0	32.0
<b>Coil Resistance</b> (Ohms ± 10% @ 25°C)	420/422, 420D/422D	61	120	280	500	1130	2000
	420DD/422DD (See Note 3)	48	97	280	500	1130	2000
<b>Coil Current (mADC @ 25°C)</b> 420DD/422DD Series only	Min.	75.8	46.9	26.0	20.0	13.7	11.6
	Max.	104.2	63.0	33.7	25.5	17.2	14.4
<b>Set &amp; Reset Voltage (VDC, Max.)</b>	420/422 420D/422D	3.5	4.5	6.8	9.0	13.5	18.0
	420DD/422DD	4.5	5.5	7.8	10.0	14.5	19.0

**PERFORMANCE CURVES**  
(NOTE 2)

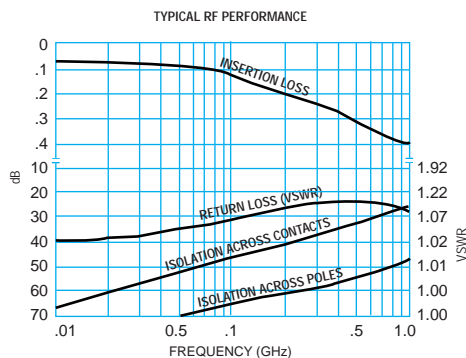

FIGURE 1

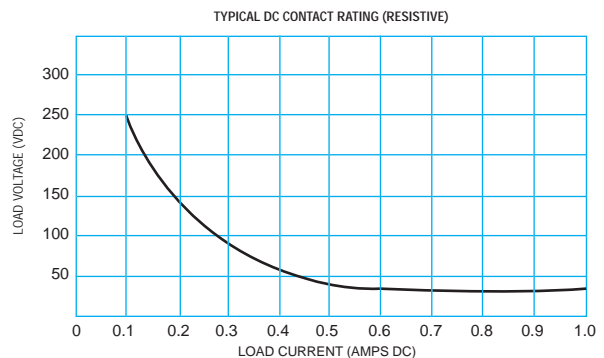
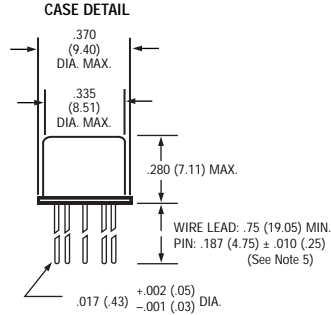
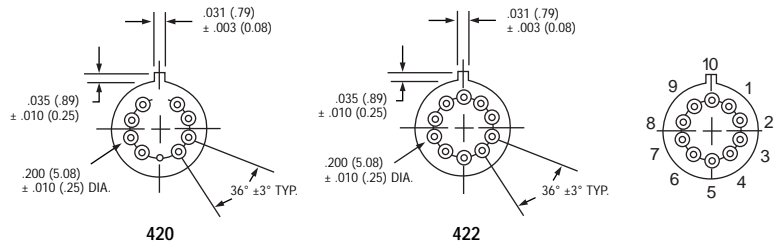

FIGURE 2

OUTLINE DIMENSIONS



TERMINAL LOCATIONS AND PIN NUMBERING (REF. ONLY)  
(Viewed from Terminals)



DIMENSIONS ARE SHOWN IN INCHES (MILLIMETERS)

SPACER PAD

Relays can be supplied with a spacer pad attached to the relay header. The pad permits the relay to be spaced away from the mounting surface facilitating solder joint inspection. To order add **M4** to the part number (e.g. 42XM4-26A).

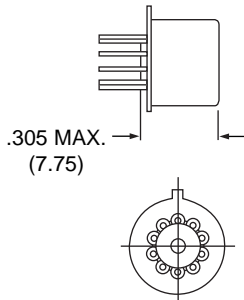

NOTES:

1. Material: Polyester film.
2. Increase contact resistance by 0.01 ohm.

SPREADER PAD

Relays can be supplied with spreader pads which are attached to the relays. Spreader pads can be supplied by adding **M** to the part number (e.g. 42XM-26A).

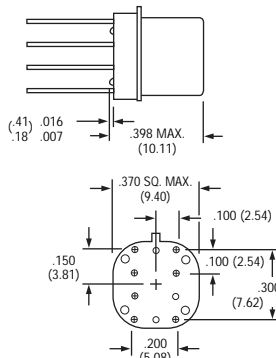

NOTES:

1. Material: Diallyl Phthalate.
2. Increase contact resistance by 0.025 ohm.

SCHEMATIC DIAGRAMS

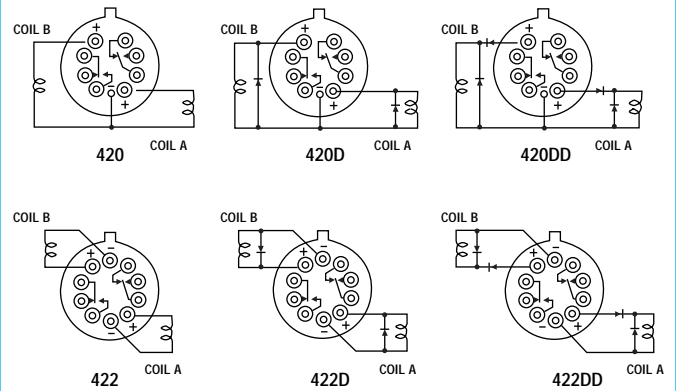

SCHEMATICS ARE VIEWED FROM TERMINALS  
CONTACTS SHOWN IN POSITION RESULTING WHEN COIL A LAST ENERGIZED.

NOTES:

1. Relay contacts will exhibit no chatter in excess of 10 µsec or transfer in excess of 1 µsec.
2. "Typical" characteristics are based on available data and are best estimates. No on-going verification tests are performed.
3. For reference only. Coil resistance not directly measurable at relays terminals due to internal series semiconductor. 420DD AND 422DD only.
4. Screened HI-REL versions available. Contact factory.
5. Unless otherwise specified, relay will be supplied as follows: Length will be standard 0.75" (19.05) minimum and will be either gold plated or solder coated. Contact your local representative for ordering information.
6. The slash and characters appearing after the slash are not marked on the relay.
7. Unless otherwise specified, parameters are initial values.

RELIABILITY LEVEL	FAILURE RATE %/10,000 CYCLES
A	1.5
B	0.75

9. Teledyne Part Numbering System for Established Reliability Relays (See T<sup>2</sup>R<sup>®</sup> Program Introduction)

EXAMPLE:

